

1 2 3 4 7 8 9 10 11

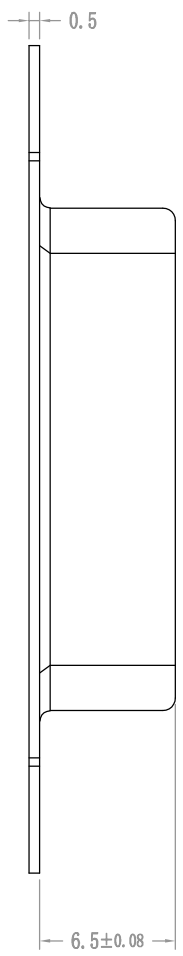
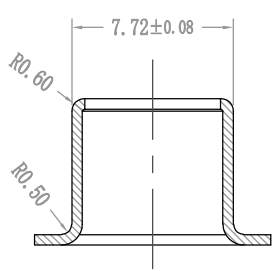
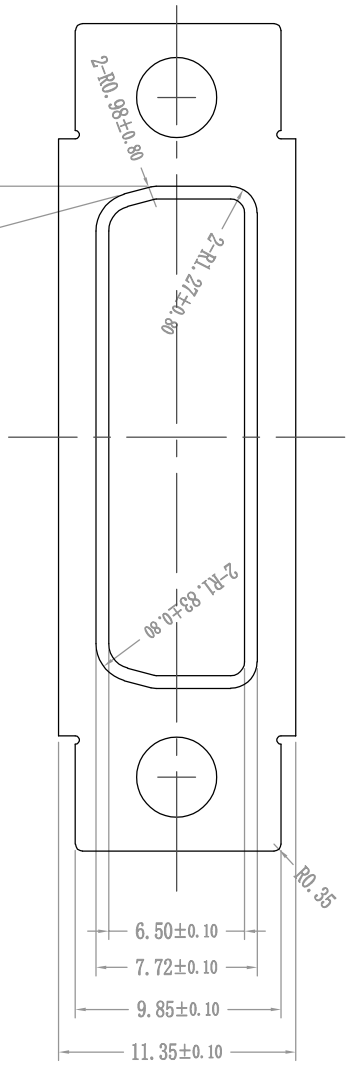

材质: SPCC, T=0.5mm;  
 电镀规格: cu: 120u以上, ni80~120u  
 产品鹽霧測試要求10H, 無氧化生鏽, 電鍍層脫落不良。  
 (試驗條件: NaCl 濃度5%, 溫度 $35 \pm 2^\circ$ , 時間10H, PH6.5~7)  
 高溫測試: 190°C-260°C, 高溫十分鐘。(高溫後不可有發黃、黃  
 點、起泡、色差、生鏽等現象。)

REV.	DCN NO.	DESCRIPTION	APPROVED/DATE

公差 (TOLERANCE)		樣本 (APP'D):		品名 (TITLE):	
X.X	$\pm 0.10$	校對 (CHECK):		DVI 鐵壳	
X.XX	$\pm 0.05$	繪圖 (DRAW):			
X.XXX	$\pm 0.03$	單位 (UNIT): mm			
ANG X.X'	$\pm 1.0^\circ$	比例 (SCALE): 1:1			
ANG X.XX	$\pm 0.5^\circ$				
重點檢數 "▲"					
				SPCC拉條料	頁次 (SHEET):